

# The JA-118N Bus signal PG output module - 8 outputs

The JA-118N is a component of the **JABLOTRON 100** system. It provides eight opto-isolated outputs. It can serve for controlling optical indication devices, radio communicators or power relays. Outputs can be controlled with a programmable control panel (PG) output or according to the status of a section (armed = output ON) or when there is an alarm in the selected section (alarm = output ON). The module also provides current-limited output 12V. It should be installed by a trained technician with a valid certificate issued by an authorized distributor.

## Installation

The module can be installed into the JA-190PL mounting box (by Jablotron) or on a DIN rail using a suitable holder.

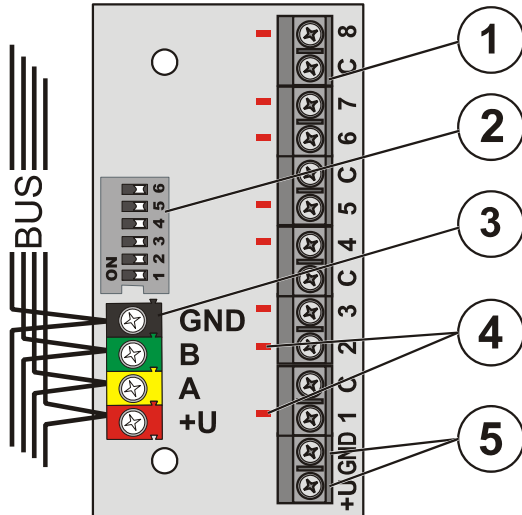

Figure: 1 – output terminals; 2 – configuration switch, 3 – digital bus terminals; 4 – indicator LEDs; 5 – power output up to 100mA

1. Use the switch (2) to set the required number of the PG output or the number of the section to which control panel output (1) should react – see the configuration tables. The terminals (outputs) on the board will then react to the following PG outputs or system sections (according to their sequence).
2. Connect bus wires to the terminals (3).

**When connecting the module to the system digital bus, always switch the power off.**



**If the module is installed outside the protected area, the JA-110T bus insulator should be used for the external section of the wiring.**

3. Switch on the system and test its functioning – a triggered output is indicated with a red LED indicator at the output (4).
4. Terminals (outputs) 1 – 8 are triggered relative to the C terminals. The output through-current must not exceed 100mA. Check the supply voltage at the bus terminals (red, black) when all outputs including the connected devices are activated. The voltage must be at least 9V. All devices powered by the terminals (5) must be connected during this test.

### Notes:

- The module does not occupy a position/address in the control panel (it is not enrolled to the system).
- Module terminals 2 to 8 are assigned according to the position selected on the configuration switch (e.g.: If PG7 is selected, then 1=PG7, 2=PG8, 3=PG9, ... 8=PG14. The same rule applies to sections).
- If module terminals 2 to 8 exceed the scope of the table, they are not triggered (e.g.: If PG30 is selected, then terminal 1=PG30, 2=PG31, 3=PG32 and terminals 4 to 8 have no function. The same rule applies to sections).
- If you connect multiple modules with identical settings to the bus, they will have the same function.
- The number of modules is only limited by the power consumption from the digital bus.
- The setting of individual programmable outputs is done in the **PG outputs** window in the F-Link program. A detailed description of the setting is available in the control panel installation manual.

- When the output is set according to the SECTION SET table, it is triggered if the section is fully armed.
- When the output is set according to the SECTION ALARM table, it is triggered if there is external or internal warning (EW or IW).
- A current of up to 100mA can be drawn from the +U terminals. If the current consumption is higher (overload), the voltage is disconnected. If the current consumption drops, the voltage is automatically reconnected.

ON 1 2 3 4 5 6	PG 1	ON 1 2 3 4 5 6	PG 9	ON 1 2 3 4 5 6	PG 17	ON 1 2 3 4 5 6	PG 25
ON 1 2 3 4 5 6	PG 2	ON 1 2 3 4 5 6	PG 10	ON 1 2 3 4 5 6	PG 18	ON 1 2 3 4 5 6	PG 26
ON 1 2 3 4 5 6	PG 3	ON 1 2 3 4 5 6	PG 11	ON 1 2 3 4 5 6	PG 19	ON 1 2 3 4 5 6	PG 27
ON 1 2 3 4 5 6	PG 4	ON 1 2 3 4 5 6	PG 12	ON 1 2 3 4 5 6	PG 20	ON 1 2 3 4 5 6	PG 28
ON 1 2 3 4 5 6	PG 5	ON 1 2 3 4 5 6	PG 13	ON 1 2 3 4 5 6	PG 21	ON 1 2 3 4 5 6	PG 29
ON 1 2 3 4 5 6	PG 6	ON 1 2 3 4 5 6	PG 14	ON 1 2 3 4 5 6	PG 22	ON 1 2 3 4 5 6	PG 30
ON 1 2 3 4 5 6	PG 7	ON 1 2 3 4 5 6	PG 15	ON 1 2 3 4 5 6	PG 23	ON 1 2 3 4 5 6	PG 31
ON 1 2 3 4 5 6	PG 8	ON 1 2 3 4 5 6	PG 16	ON 1 2 3 4 5 6	PG 24	ON 1 2 3 4 5 6	PG 32

Table 1: Output 1 reacts to the PG output state.

ON 1 2 3 4 5 6	SC 1	ON 1 2 3 4 5 6	SC 9	ON 1 2 3 4 5 6	AL 1	ON 1 2 3 4 5 6	AL 9
ON 1 2 3 4 5 6	SC 2	ON 1 2 3 4 5 6	SC 10	ON 1 2 3 4 5 6	AL 2	ON 1 2 3 4 5 6	AL 10
ON 1 2 3 4 5 6	SC 3	ON 1 2 3 4 5 6	SC 11	ON 1 2 3 4 5 6	AL 3	ON 1 2 3 4 5 6	AL 11
ON 1 2 3 4 5 6	SC 4	ON 1 2 3 4 5 6	SC 12	ON 1 2 3 4 5 6	AL 4	ON 1 2 3 4 5 6	AL 12
ON 1 2 3 4 5 6	SC 5	ON 1 2 3 4 5 6	SC 13	ON 1 2 3 4 5 6	AL 5	ON 1 2 3 4 5 6	AL 13
ON 1 2 3 4 5 6	SC 6	ON 1 2 3 4 5 6	SC 14	ON 1 2 3 4 5 6	AL 6	ON 1 2 3 4 5 6	AL 14
ON 1 2 3 4 5 6	SC 7	ON 1 2 3 4 5 6	SC 15	ON 1 2 3 4 5 6	AL 7	ON 1 2 3 4 5 6	AL 15
ON 1 2 3 4 5 6	SC 8	SECTION: SET		ON 1 2 3 4 5 6	AL 8	SECTION: ALARM	

Table 2: Output 1 reacts to the arming of the selected section

Table 3: Output 1 reacts to an alarm in the selected section

## Technical specifications

Power	from control panel digital bus 12V (9...15V)
Current consumption in standby mode	outputs off/on 5mA / 10mA
Current consumption for cable selection	10mA
Maximum current from +U output (electronic fuse)	<100mA
(all connected devices must be included in current calculations)	
Maximum switched current / voltage for each output	100mA / 38V
Dimensions	77 x 40 x 15 mm
Classification	Grade II
according to	EN 50131-1, EN 50131-3
Operational environment according to EN 50131-1 II	indoor general
Operating temperature range	-10°C to +40°C
Also complies with	EN 50130-4, EN 55022



JABLOTRON ALARMS a.s. hereby declares that the JA-118N is in compliance with the essential requirements and other relevant provisions of Directive 2004/108/EC. The original of the conformity assessment can be found at [www.jablotron.com](http://www.jablotron.com) - Technical Support section



**Note:** Although this product does not contain any harmful materials we suggest you return the product to the dealer or directly to the producer after use. For more detailed information visit [www.jablotron.com](http://www.jablotron.com).